

# BRONZE GATE VALVE

- 200 W.O.G.
- Solid Wedge Disc
- Non-rising Stem
- Screwed Ends & CxC

## NOMENCLATURE AND MATERIALS

NO.	PART	MATERIAL	SPEC.JIS	SPEC.ASTM	NO.	PART	MATERIAL	SPEC.JIS	SPEC.ASTM
1	WHEEL NUT	STEEL	S10C	AISI-1010	6	GLAND	BRASS	C3604B	B16-C36000
2	NAME PLATE	ALUMINUM	A1100P	B209-1100	7	GLAND PACKING	GRAPHITE	COMMERCIAL	COMMERCIAL
3	HAND WHEEL	CAST IRON	FC20	A48 CLASS/NO:35	8	BONNET	CAST BRONZE	BC6	B584-C83600
4	STEM	BRASS	C3604B	B16-C36000	9	LOCK NUT	BRASS	C3604B	B16-C36000
5	PACKING NUT	BRASS	C3604B	B16-C36000 (1/4"-1")	10	DISC	CAST BRONZE	BC6	B584-C83600
		CAST BRASS	YBSC3	B584-C85700 (1/4"-4")	11	BODY	CAST BRONZE	BC6	B584-C83600

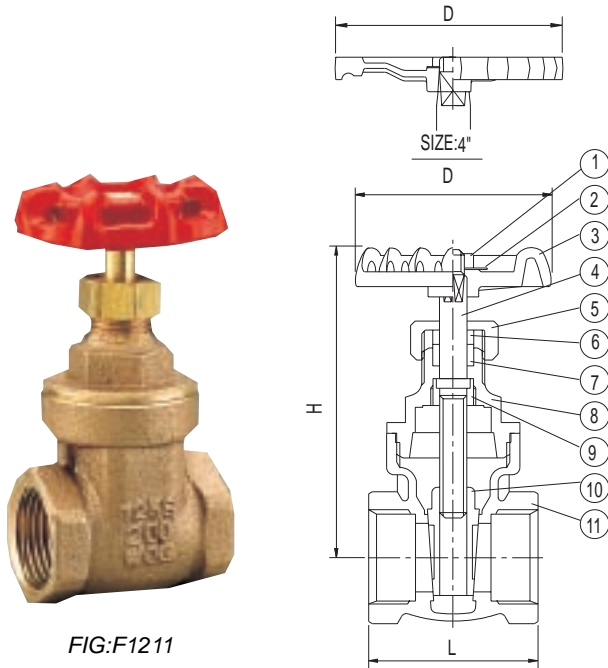

FIG:F1211

NOMINAL SIZE	DIMENSION (mm)				PCS	
	L	L1	H	D	Carton	Case
1/4"	41	/	70	54	120	300
3/8"	41	40	70	54	120	300
1/2"	43	45	72	54	120	300
3/4"	47	59	84	54	90	200
1"	54	70	98	61	60	150
1 1/4"	61	73	116	77	40	100
1 1/2"	62	81	125	77	32	80
2"	72	99	153	83	20	60
2 1/2"	89	117	186	105	12	30
3"	101	132	222/220	130/112	8	20
4"	116	/	249/258	172/132	4	9

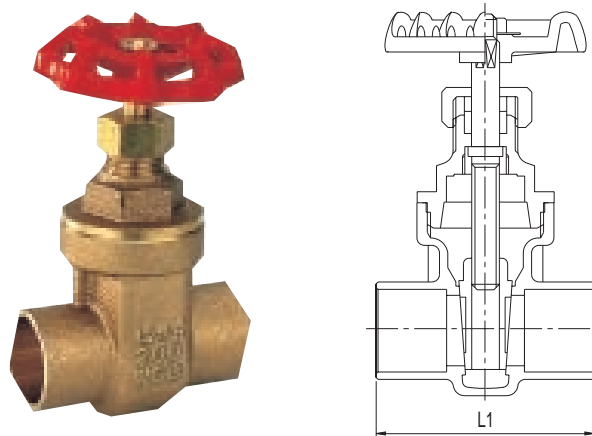

FIG:F1212