

BRASS & BRONZE SWING CHECK VALVE

• 200 W.O.G.

• Screwed Ends & CxC



(F1151S · F1152S only)

NOMENCLATURE AND MATERIALS

NO.	PART	MATERIAL	SPEC.JIS	SPEC.ASTM	NO.	PART	MATERIAL	SPEC.JIS	SPEC.ASTM
1	COVER	CAST BRASS	YBSC3	B584-C85700	3	DISC	FORGED BRASS	C3771B	B124-C37700
		CAST BRONZE	BC6	B584-C83600			CAST BRONZE	BC6	B584-C83600
2	BODY	CAST BRASS	YBSC3	B584-C85700	4	PIN	BRASS	C3604B	B16-C36000
		CAST BRONZE	BC6	B584-C83600	5	SCREW	BRASS	C3604B	B16-C36000



BRASS FIG:F1151S
BRONZE FIG:F1251S



BRASS FIG:F1152S
BRONZE FIG:F1252S

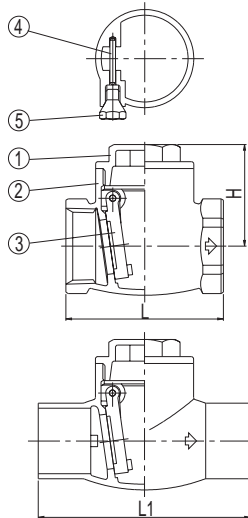

DIMENSIONS-QUANTITIES / F1151S & F1152S / F1251S & F1252S

NOMINAL SIZE	DIMENSION (mm)			PCS	
	L	H	L1	Carton	Case
1/2"	52	38	53	160	400
3/4"	59	40	75	120	300
1"	69	45	92	72	180
1 1/4"	79	51	103	60	150
1 1/2"	89	55	115	32	100
2"	109	67	139	24	60
2 1/2"	135	84	/	12	32
3"	160	96	/	6	24
4"	190	113	/	4	12

BRASS & BRONZE GLOBE VALVE

• 125 W.O.G.

• Screwed Ends

NOMENCLATURE AND MATERIALS

NO.	PART	MATERIAL	SPEC.JIS	SPEC.ASTM	NO.	PART	MATERIAL	SPEC.JIS	SPEC.ASTM
1	NUT	STEEL	S10C	AISI-1010	6	GLAND PACKING	RUBBER	SAME AS NBR	SAME AS NBR
2	NAME PLATE	ALUMINUM	A1100P	B209-1100	7	BONNET	FORGED BRASS	C3771B	B124-C37700
3	HAND WHEEL	CAST IRON	FC20	A48 CLASS/NO.35	8	BODY	CAST BRASS	YBSC3	B584-C85700
4	STEM	BRASS	C3604B	B16-C36000			CAST BRONZE	BC6	B584-C83600
5	PACKING NUT	BRASS	C3604B	B16-C36000	9	DISC	BRASS	C3604B	B16-C36000



BRASS: FIG/F1131
BRONZE: FIG/F1231

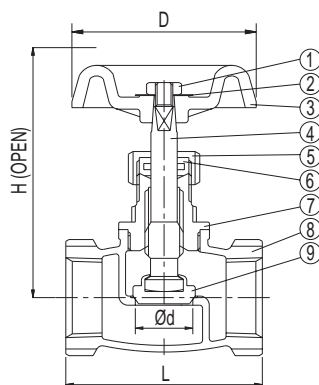

DIMENSIONS-QUANTITIES / F1131 & F1231

NOMINAL SIZE	DIMENSION (mm)				PCS	
	L	H	D	d	Carton	Case
1/2"	48	68	54	12.5	120	300
3/4"	53	77	54	13.5	100	300
1"	63	86	61	19	60	180
1 1/4"	73	101	75	24	40	100
1 1/2"	81	106	75	32	32	80
2"	94	130	81	38	20	60